



## **Strategic Versatility**

**SMS1, RB1, SB1, SS1**



*One design,  
Four Integrated Seals*



**SB1**



## Versatility Means Savings and Reliability

**SMS1**

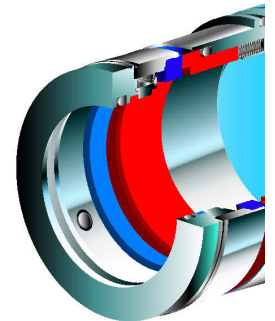

With common sleeves, glands, and seal parts for all designs, cartridge assembly is quick and fail-safe. Plus, it's easy to modify face material, metallurgy and elastomers. This strategic grouping covers 80%

**There are Clear Reasons  
to Employ the  
Integrated Cartridge  
System**

of industries' sealing applications. The efficiency gained allows aggressive price structures and even low-cost repair kits and exotic

alloys at substantial savings. Flex-A-Seal's famous premium welded bellows designs are included at multiple spring prices.

Downstream, the benefits start with quick deliveries, allowing customers to minimize inventories through various exchange programs.

Design advantages are: simple, easy-to-install cartridge designs; sleeves that are isolated from the product; fewer "O" rings and rugged machined construction.

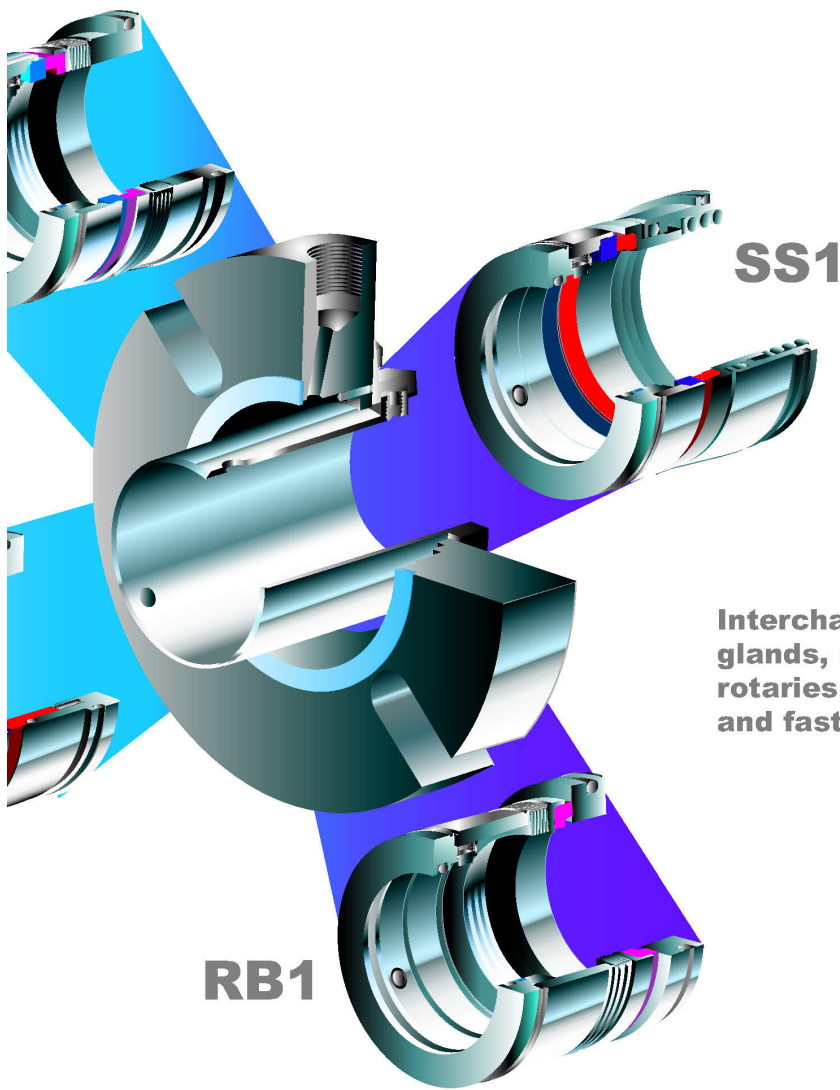

**Interchangeable sleeves,  
glands, clips, faces,  
rotaries, seats, "O" rings,  
and fasteners.**

**RB1**

Traditional cup point set screws in rotating units are replaced by a patent pending Plunger-Lock drive. The torque transmission strength is increased 5 fold over traditional cup point set screws. Most importantly, it allows for quick/easy assembly and seal-kit replacement.

The entire drive mechanism is out of product. This system eliminates any possibility of sleeve distortion from overtightened set screws. There are no set screws to "back out". The spring-loaded mechanism keeps the lug "trapped" in position.

**No more difficult  
set screws. Our  
unique, Plunger-  
Lock Drive makes  
assembly easy.  
(Patent Pending)**

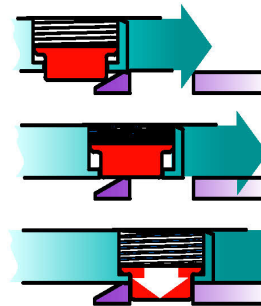



## SMS1 Stationary Multiple Spring Cartridge

rotating mating ring for better face alignment and heat dissipation

stationary springs isolated from the process

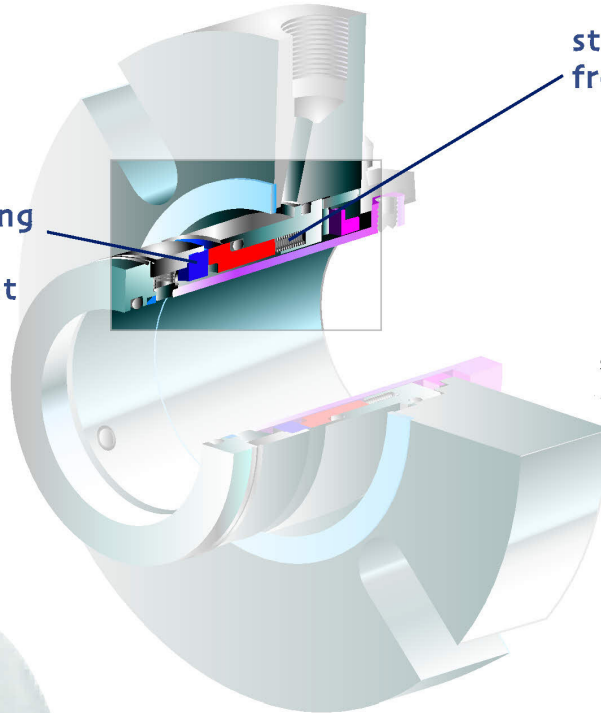

flush connection

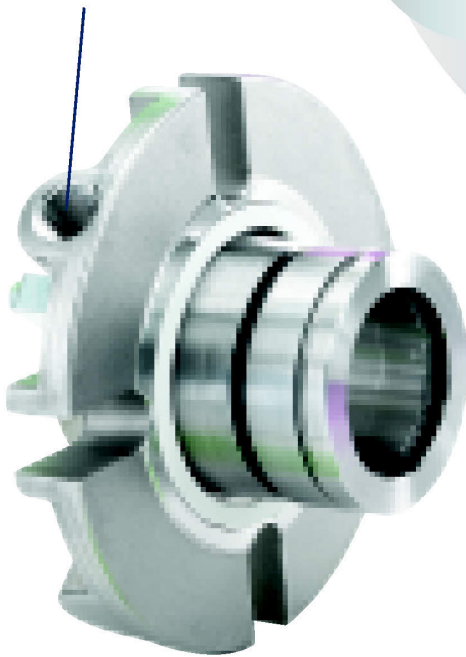

SMS1	
Rotary Face	Silicon Carbide
Stationary Face	Carbon
	Silicon Carbide
Springs	Hast** C
Metal Parts	316 SS/17-4 316 SS Hast** C276 Consult factory for special alloys
"O" Rings	Viton®+ Ethylene Propylene AFLAS* Perfluoroelastomer
Max. Temp.	400°F*** (200 °C)
Max. Pressure	300 PSI (carbon)(20 BAR) consult factory for higher pressures
Max. Speed	6000 fpm

\*\*\*Certain "O" rings will lower temperature limitations  
+Viton® is a DuPont Performance Elastomer  
\*Asahi Glass Company Ltd. Registered Trademark  
\*\*Cabot Stellite Div. Registered Trademark

- FAS' most cost effective cartridge design
- monolithic face w/ homogenous material
- drive mechanisms out of product
- springs are out of product, minimizes corrosion and stress related failure
- unique shrouded rotary for maximum face protection and reliable startup
- uniform 360 degree transfer of torque to rotating face

- seal faces positioned in gland for maximum protection
- dynamic elastomer moves on non-metallic surface eliminating fretting
- faces designed for optimum heat dissipation
- sleeve is isolated from product
- hydraulically balanced
- easy cartridge installation
- flush position maximizes face cooling
- fits all standard and large bore ANSI pumps
- **SMS3 FV&D** all benefits of SMS1 plus with vent and drain connections made to different sizes to assure that correct piping plans are employed
- very cost effective upgrade

## RB1 Rotating Welded Bellows Cartridge

- only 4 primary assembled parts
- faces, metallurgies and elastomers are easily upgradeable
- self cleaning
- easy cartridge installation
- hydraulically balanced design
- no springs to break or clog
- flush position maximizes cooling
- fits all standard and big bore ANSI pumps
- uniform 360° transfer of torque to primary rotating face
- sleeve is isolated from product
- **RB3 FV&D** all benefits of RB1 plus with vent and drain connections made to different sizes to assure that correct piping plans are employed

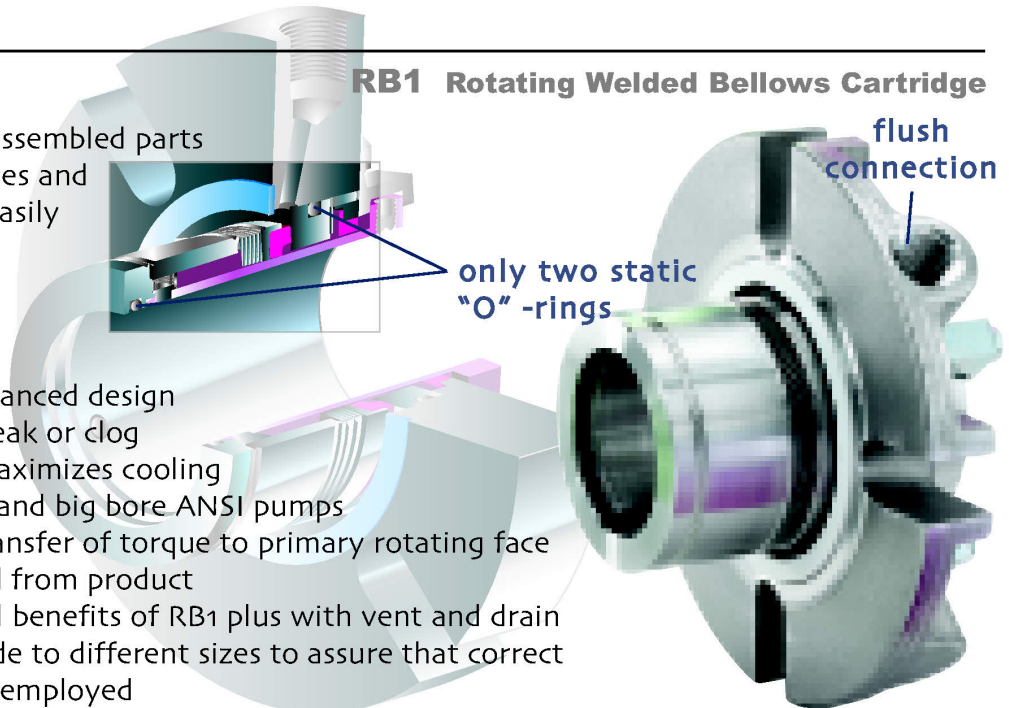

## SB1 Stationary Welded Bellows Cartridge

stationary bellows for maximum face alignment

flush connection

- faces designed for optimum heat dissipation
- shrouded rotary seal ring for maximum face protection and reliable start-up
  - easy cartridge installation
  - no dynamic elastomers
  - hydraulically balanced design
  - even face loading
  - flush position maximizes face cooling
  - fits all standard and big bore ANSI pumps
  - uniform 360° transfer of torque to the primary rotating face
- only 2 static "O" rings
- sleeve is isolated from product
- **SB3 FV&D** all benefits of SB1 plus with vent and drain connections made to different sizes to assure that correct piping plans are employed
- very cost effective upgrade

	RB1	SB1
Rotary Face	Carbon Nickel Tungsten Carbide Silicon Carbide	Silicon Carbide
Stationary Face	Silicon Carbide	Carbon Nickel Tungsten Carbide Silicon Carbide
Metal Parts	Hastelloy**C 276 316 SS	Hastelloy**C276 316 SS/17-4 316 SS Hast**C276
"O" Rings	consult factory for special alloys Viton®+ Ethylene Propylene AFLAS* Perfluoroelastomer TJV®+	Viton®+ Ethylene Propylene AFLAS* Perfluoroelastomer TJV®+
Max. Temp.	400°F (200°C) consult factory for higher temps.	400°F(200°C) consult factory for higher temps.
Max. Pressure	300 PSI(20 BAR)	300 PSI(20 BAR)
Max. Speed	4500 fpm	6000 fpm

\*\*\* Certain "O" rings will lower temperature limitations  
 \*Viton® is a DuPont Performance Elastomer \*Asahi Glass Company Ltd. Registered Trademark \*\*Cabot Stellite Div. Registered Trademark



## SS1 Stationary Single Spring Cartridge

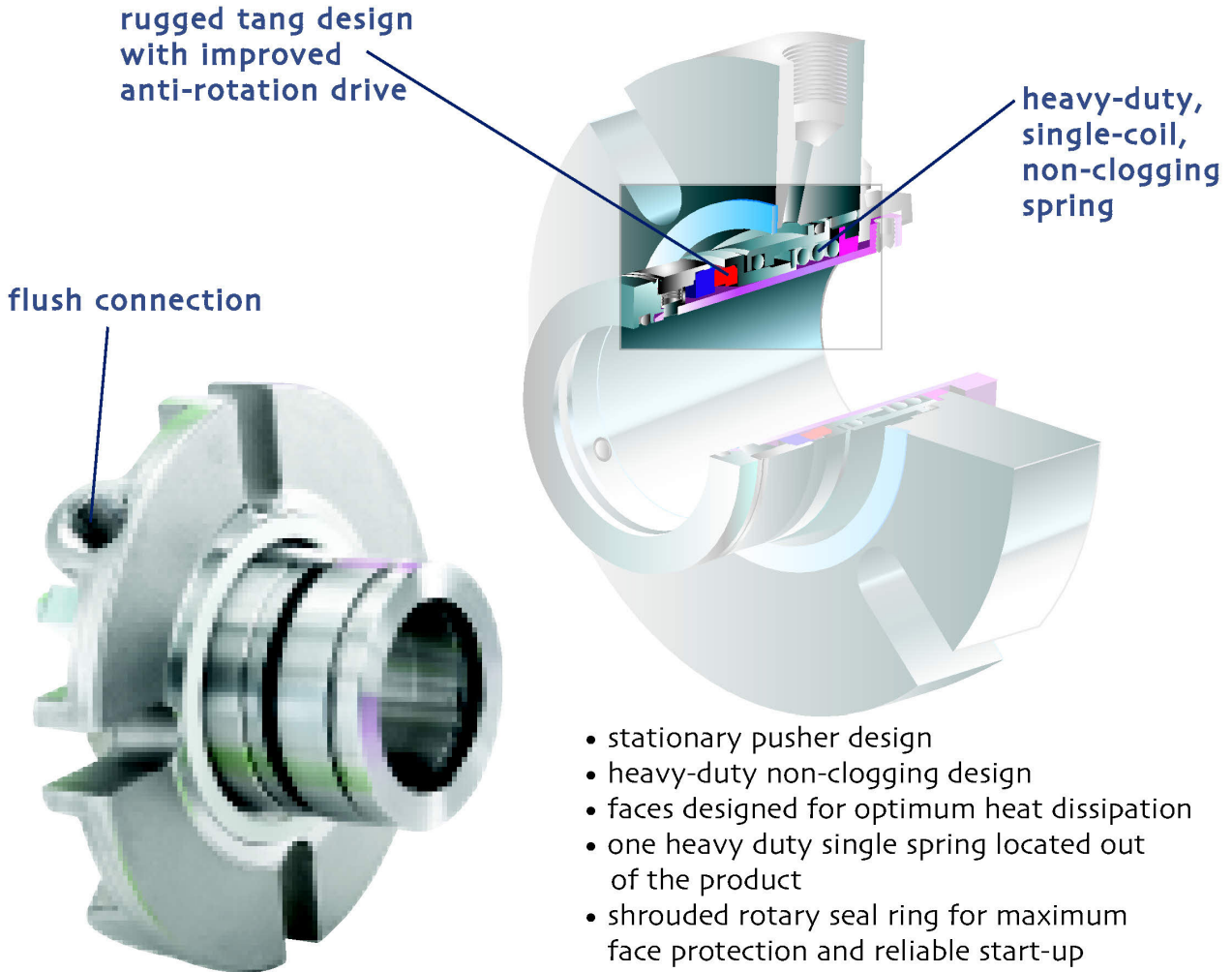

- stationary pusher design
- heavy-duty non-clogging design
- faces designed for optimum heat dissipation
- one heavy duty single spring located out of the product
- shrouded rotary seal ring for maximum face protection and reliable start-up
- uniform 360° transfer of torque to primary rotating face
- upgradeable faces, metallurgies, and elastomers
- sleeve is isolated from product
- hydraulically balanced
- easy cartridge installation
- flush position maximizes face cooling
- fits all standard and large bore ANSI pumps

### SS3 FV&D

- all benefits of SS1 plus with vent and drain connections made to different sizes to assure that correct piping plans are employed
- very cost effective upgrade

SS1	
Rotary Face	Silicon Carbide
Stationary Face	Silicon Carbide Carbon Nickel/Tungsten Carbide
Springs	316 SS
Metal Parts	316 SS/17-4SS 316 SS/Hast**C276 Consult factory for special alloys
"O" Rings	Viton®+ Ethylene Propylene AFLAS* Perfluoroelastomer
Max. Temp.	400° F*** (200°C)
Max. Pressure	300 PSI (20Bar)
Max. Speed	6000 FPM

\*\*\* Certain "O" rings will have lower temperature limitations

+Viton® is a DuPont Performance Elastomer

\*Asahi Glass Company Ltd. Registered Trademark

\*\*Cabot Stellite Div. Registered Trademark

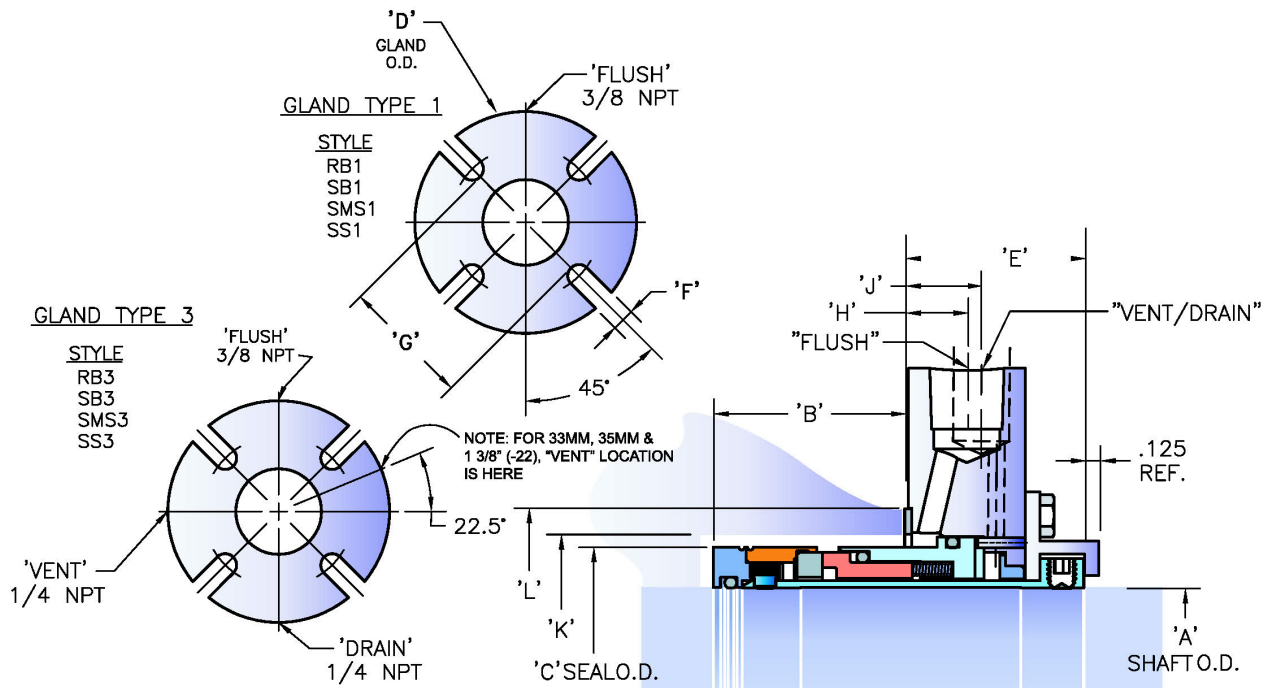

Seal Size	A	(Metric)**	B	C	D	E	F	G	H	J	K <sub>(gasket)</sub>	L <sub>(gasket)</sub>
-16	1.000	24mm	1.633	1.700	4.000	1.531	.437	2.375	.531	.657	1.790	2.230
-16	1.000	25mm	1.633	1.700	4.000	1.531	.437	2.375	.531	.657	1.790	2.230
-18	1.125	28mm	1.633	1.700	4.250	1.531	.437	2.462	.531	.657	1.915	2.355
-20	1.250	30mm	1.633	1.950	4.250	1.531	.437	2.583	.531	.657	2.040	2.480
		32mm	1.633	1.950	4.250	1.531	.437	2.583	.531	.657	2.040	2.480
-22	1.375	33mm	1.633	1.950	4.250	1.531	.437	2.712	.531	.657	2.165	2.605
		35mm	1.633	1.950	4.250	1.531	.437	2.712	.531	.657	2.165	2.605
-24	1.500	38mm	1.633	2.200	4.500	1.531	.562	2.950	.531	.657	2.415	2.855
-26	1.625	40mm	1.633	2.325	5.000	1.531	.562	3.075	.531	.657	2.540	2.990
-28	1.750	43mm	1.633	2.450	5.500	1.531	.562	3.188	.531	.657	2.665	3.105
		45mm	1.633	2.450	5.500	1.531	.562	3.188	.531	.657	2.665	3.105
-30	1.875	48mm	1.633	2.575	5.500	1.531	.562	3.313	.531	.657	2.790	3.230
-32	2.000	50mm	1.582	2.700	5.500	1.594	.562	3.570	.562	.719	3.040	3.490
-34	2.125	53mm	1.582	2.825	6.000	1.594	.687	3.687	.500	.719	3.165	3.605
-36	2.250	55mm	1.539	2.950	6.250	1.656	.687	3.813	.593	.782	3.290	3.730
-38	2.375	58mm	1.714	3.195	6.250	1.656	.687	3.937	.531	.782	3.415	3.855
		60mm	1.714	3.195	6.250	1.656	.687	3.937	.531	.782	3.415	3.855
-40	2.500	63mm	1.650	3.320	6.500	1.720	.687	3.937	.500	.845	3.500	3.855
-42	2.625	65mm	1.650	3.560	6.500	1.720	.687	4.188	.500	.845	3.625	4.070
-44	2.750	68mm	1.589	3.650	7.500	1.781	.687	4.438	.500	.907	3.820	4.320
		70mm	1.589	3.650	7.500	1.781	.687	4.438	.500	.907	3.820	4.320
-46	2.875	72mm	1.712	3.785	7.500	1.781	.687	4.625	.656	.907	3.950	4.450
-48	3.000	75mm	1.822	3.900	8.000	1.781	.687	5.062	.656	.907	4.075	4.825
-50	3.125	n/a	1.970	4.050	8.000	1.781	.687	5.062	.656	.907	4.200	4.825
-52	3.250	80mm	1.922	4.175	8.250	1.781	.687	5.187	.656	.907	4.325	4.950
-54	3.375	85mm	1.970	4.300	8.500	1.781	.812	5.312	.656	.907	4.450	5.075
-56	3.500	n/a	1.860	4.430	8.500	1.843	.812	5.438	.687	.969	4.575	5.200
-58	3.625	90mm	1.908	4.555	8.500	1.843	.812	5.562	.687	.969	4.700	5.325
-60	3.750	95mm	1.860	4.680	8.750	1.843	.812	5.688	.687	.969	4.825	5.450
-62	3.875	n/a	1.908	4.900	8.750	1.843	.812	5.812	.687	.969	4.950	5.575
-64	4.000	100mm	1.750	5.150	9.000	1.843	.812	6.063	.687	.969	5.325	5.950
ANSI large bore												
-22	1.375	33mm	1.633	1.950	5.250	1.531	.437	3.563	.531	.657	2.875	3.375
-28	1.750	40mm	1.633	2.450	6.500	1.531	.563	4.937	.531	.657	3.570	4.070
-30	1.875	43mm	1.633	2.575	6.000	1.531	.563	4.437	.531	.657	3.625	4.070
-40	2.500	55mm	1.650	3.320	8.000	1.720	.688	6.063	.500	.845	4.700	5.325
-42	2.625	58mm	1.650	3.560	7.000	1.720	.563	5.437	.500	.845	4.625	5.125

\*\*Indicate metric when ordering

Flex-A-Seal offers a line of welded metal bellows seals to handle extreme high-heat operating conditions. Full technical specification and application information is available upon request.

## Styles 60/62/64/66

### High Temperature Solutions



#### Capabilities include:

- Temperatures to 800°F/425°C
- Compatible metallurgy for high temperatures
- High temperature static grafoil packing throughout
- Balanced design - pressures to 300 PSI
- Self-cleaning
- Stationary and drive lug options
- Cartridge designs available
- Single and double-ply AM350, Inconel 718 bellows available
- Easy installation
- Individual connection sizes to assure proper piping
- Easily upgradeable to API design specifications

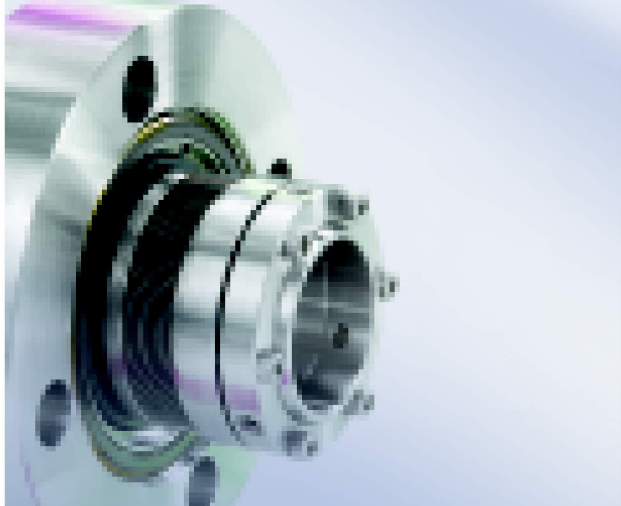

#### Manufacturing and stocking centers

##### USA

1 Jackson Street PO Box 184  
Essex Junction, VT 05453-0184 USA  
Phone: 1-800-426-3594 • 1-802-878-8307  
Fax: 1-802-878-2479  
Email: sales@flexaseal.com

##### BRAZIL

Rua Visconde De Taunay  
59 Loja 06-CEP  
Bom Retiro, Sao Paulo  
Brazil CEP 01132-000  
Phone: 55-11-3115-4819 • 55-11-3115-0656  
Fax: 55-11-3101-1297  
Email: vendas@flexaseal.com.br

##### AUSTRALIA

Unit 9/23 Richland Avenue  
Coopers Plains 4108 QLD Australia  
Phone: (07) 3272 7030  
Fax: (07) 3272 9885 Mob: 0417 626025  
Email: flexasealoz@bigpond.com

#### DISTRIBUTED BY:

